

A comprehensive range of quality pneumatic chain hoists suitable for both industrial and marine environments. Red Rooster pneumatic hoists comply with the European Machinery Directive and are CE marked. Our ISO9001:2008 Quality System is accredited by L.R.Q.A.

Standard Hoist Features:

- Toku rotary vane motor.
- Robust epicyclic gearbox (grease filled and sealed).
- Failsafe automatic internal disc brake
- Choice of pull cord or pendant control.
- Mechanical, upper and lower limit switches.
- Cast steel housing.
- Variable speed.
- Internal silencing down to 75 dBA
- Alloy safety swivel hooks c/w safety catch.
- Load chain of European manufacture EN818/1-7
- Automatic, adjustable load limiter.

Available Options:

- Marine specification
- Special paint systems
- Corrosion protection
- ATEX specification ZONE 1 & 2
- Chain collectors (P.V.C., galvanised or stainless steel).
- Air service units
- Festoon systems
- Radio control
- Main air shut off valve

MODEL	WLL	LIFTING SPEED WITH LOAD	LIFTING SPEED WITHOUT LOAD	AIR CONSUMPTION LIFTING	LOWERING SPEED WITH LOAD	AIR CONSUMPTION LOWERING
	25,000kg	0.6 m/min	1.0 m/min	90 l/sec	0.7 m/min	100 l/sec
TNC 25 TW LPE	AIR CONNECTION	MINIMUM HOSE DIAM.	WORKING PRESSURE	CHAIN FALLS	WEIGHT WITH 3M HOL	WEIGHT PER ADDITIONAL METRE HOL
	1" BSP	1" HOSE	6 bar	2	460 kg	21.8 kg

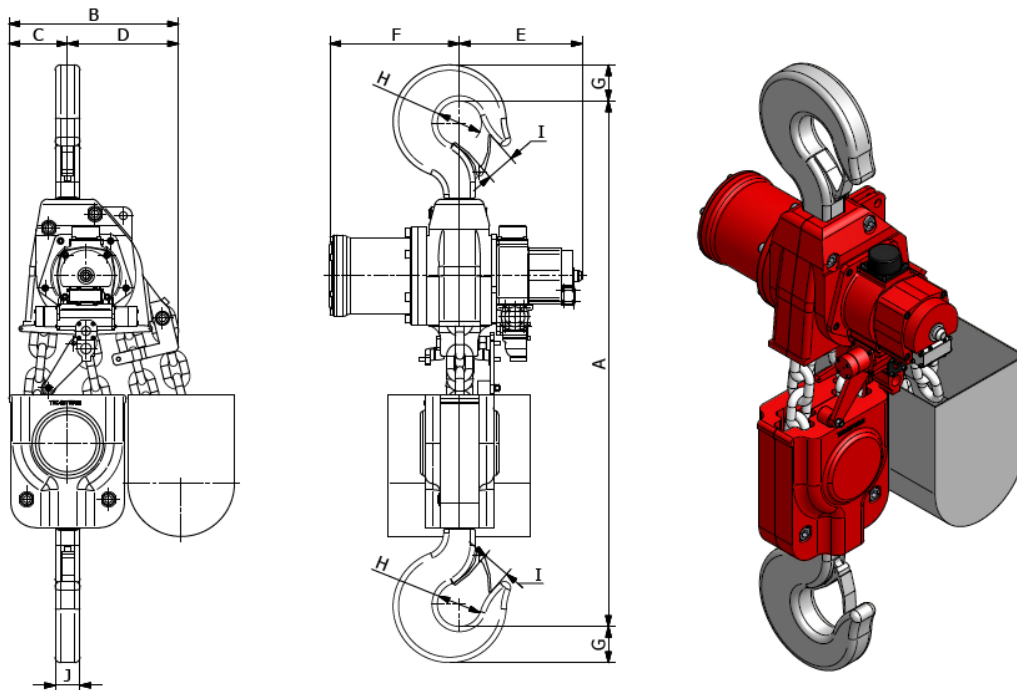

Model	A	B	C	D	E	F	G	HØ	I	J
TNC 25 TW LPE	1400	478	165	313	346	365	103	125	80	70

All measurements are in mm

For quotation purposes only. Not drawn to scale. This drawing may not include all options offered on the quotation