

Manufactured in a range of capacities from 2 tonnes to 25 tonnes utilising high strength, low weight Duralloy, with grey chromic anodised finish. The links accept standard alloy steel shackles (U.S. Federal Specification RR-C-271D e.g. Crosby, Green Pin). High quality 'Micromerements' strain gauges are used throughout the range; resin bonded and sealed to the inner faces under controlled laboratory conditions. The high-density nylon cover plates facilitate protection against water and dust ingress to IP65.

Standard Features:

- Microprocessor based digital electronics.
- 11mm liquid crystal display.
- Self-diagnostic (diagnoses faults at 'switch on' and classifies fault with error code).
- Non-corruptible single point calibration.
- Powered by Nickel Metal Hydride battery.
- Up to 16 hours continuous use between charges.
- Mains battery charger with plug.
- Robust, nylon reinforced charge plug and socket.
- Robust carry case.

Functions:

- On/Off
- Tare
- Pushbutton zero
- Low battery indication



Technical Specification			
Capacity	2t / 5t	10T	25T
Hole Diameters (mm)	28	40	54
Shackle Capacity	6.5T	13.5T	25T
Resolution	1 kg	2 kg	10kg
Accuracy % FSD	0.5%	0.5%	0.5%
Ingress Protection	IP65		
Temp Range	-10°C to +40°C		
Weight	8kg	8kg	14kg

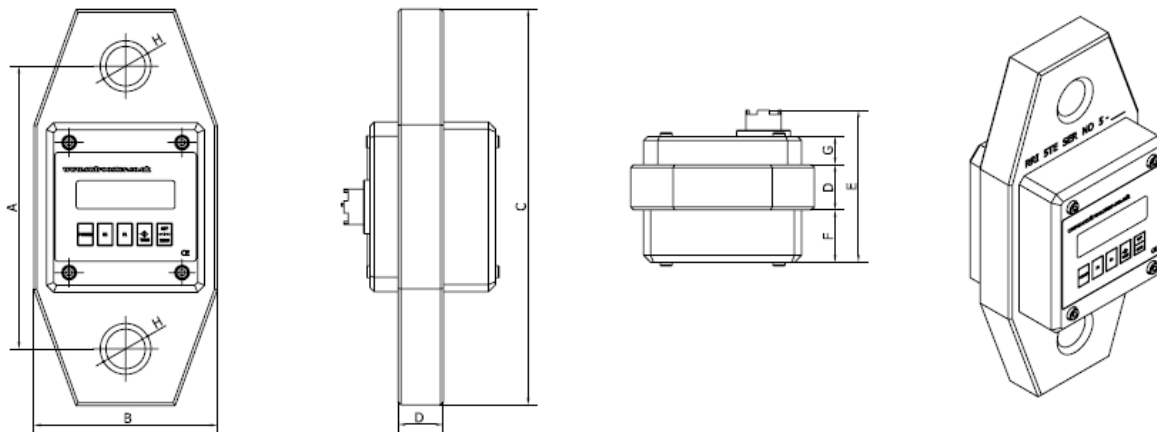

Model	A	B	C	D	E	F	G	HØ
SWL5	200	130	280	32	96	35	10	28
SWL10	230	145	330	48	112	35	10	40
SWL25	250	152	370	70	134	35	10	54

All measurements are in mm

For quotation purposes only. Not drawn to scale. This drawing may not include all options offered on the quotation